

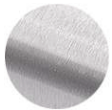

AVAILABLE FINISHES



BRUSHED
STAINLESS



BRUSHED
BRASS



POLISHED
BRASS



OIL RUBBED
BRONZE



MATTE
BLACK

SPECIAL ORDER FINISHES



POLISHED
STAINLESS

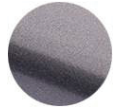

GUNMETAL
GREY

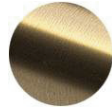

ANTIQUE
BRASS



SUNSET
COPPER

CUSTOM COLORS ARE AVAILABLE BY REQUEST

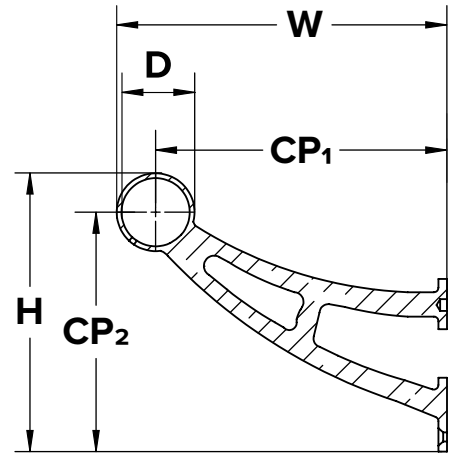

DIMENSIONS

(W)	WIDTH	7.23"
(H)	HEIGHT	6.11"
(D)	DIAMETER	1.50"
(CP ₁)	CENTER POINT 1	6.38"
(CP ₂)	CENTER POINT 2	5.24"

INCLUDES

- 3 x #10 1-1/2" Mounting Screws
- 1 x #8 3/4" Self-Drilling Set Screw

Nut & Bolt Assembly:

- 1 x Bolt - Fully threaded, 5/16" - 18 x 3"
- 1 x Hex Nut - 5/16" - 18
- 1 x USS Flat Washer - 5/16"

INSTALLATION

Bar mount brackets include a nut and bolt assembly to properly support the weight. To ensure adequate support, a solid backing at least 3/4" deep is required.

1. Measure & mark holes for mounting screws and for the threaded bolt.
2. Drill hole in bar diewall for the threaded rod.
3. Attach bracket from behind bar face using rod and secure with bolt and washer.
4. Attach brackets to the face of the bar with the 3 mounting screws.
5. Secure tubing to bracket by fastening set screws through hole in the bottom of bracket.

Care and maintenance of bar foot rail varies by finish. Given the nature of the product, typical wear and tear may be noticed with your bar rail over time, such as scuffs, scratches, and dirt. Visit kegworks.com/bar-rail-care to read our guide on how to properly prep, clean & maintain all bar rail finishes.